

460BSDFM-N2EW

Get Your Legacy DF1 PLCs Integrated into Your BACnet/IP Systems Wirelessly

FEATURES

- Fully configurable BACnet/IP server
- BACnet/IP supports device, binary I/O, analog I/O, and character string value object types
- Support for PLC5, SLC and MicroLogix PLCs
- Connect up to 32 DF1 serial devices
- Effortless Browser Based Configuration, no programming software is required
- Simple data translation allows you to manipulate data as it passes between protocols
- Guaranteed Stock
- 5-Year Hardware Warranty

Map Your Legacy PLC Data Tables into a BACnet/IP Client

You can now make your legacy serial A-B PLCs look like a BACnet/IP devices! Any of your old serial PLCs like the PLC5, SLC, or MicroLogix can now provide data to a BACnet/IP client.

It's the perfect tool to keep those old legacy PLCs from the scrap pile.

How Do I Use the 460BSDFM-N2EW in My Application?

For most applications, the mapping is very straightforward. PLC data table values like N7:200 and F9:1 are mapped directly into analog and binary objects in BACnet. The data transfer is bidirectional.

No message instructions and no ladder to alter in many cases.

Why Use Real Time Automation as a Gateway Supplier?

While there are certainly other companies offering protocol gateways, there is no one who provides the level of support and service that you receive from RTA.

When you call, a live person answers the phone. When you talk with sales, you will get honest answers and recommendations. When you get support, it is from an engineer who had a hand in the product's development, and support doesn't require a ticket or 24-hour wait.



A Solution, A Philosophy, the RTA Way. We understand the long hours spent on a factory floor and the pressure to keep a line running and product flowing. That's how Real Time Automation came to be. You want easy-to-use solutions where the hardest part is to open the box. You need customer support second to none. If you get all that and a fun customer experience all the better. Thirty years later, our mission remains the same: **To move your data where you need it, when you need it, and how you need it.**

BACnet/IP Server	
Operation Mode	BACnet/IP Server
Supported Object Types	Device, Binary I/O, Analog I/O, Character String Value
Supported Service Codes	Read & Read Multiple-B, Write & Write Multiple-B, COV & COV unsolicited-B, Device Dynamic Binding-B, Dynamic Object Binding-B
Maximum Connections	1
Analog Objects Supported	1200 Input and 1200 Output
Binary Objects Supported	1600 Input and 1600 Output
DF1 Master	
Operation Mode	DF1 Master Full Duplex and DF1 Master Half Duplex
PLCs Supported	MicroLogix 1000, SLC 5/03 5/04 5/05, most PLC5s
Maximum number of Devices supported	1 in Full Duplex Mode, 32 in Half Duplex
Data Type Supported	100 Integers or 100 Binaries, or 50 floats, 82 character string per Scan line
Scan Lines	100 input / 100 output
Physical Connections	RS-485 and RS-232
INCLUDED WITH GATEWAY	
3' power cable with flying leads	5-year hardware warranty
IPSetup software – automatically locates RTA gateway on the network	Unlimited firmware feature upgrades for life
CAT5 crossover cable for direct connection to PC during programming	Complete, unlimited access to our industry leading support staff
Optional: Generic 1761-CBL-PM02 Cable	Optional: NULL Modem Cable

ELECTRICAL / ENVIRONMENTAL	
DC Input Voltage	12-24 VDC
Maximum Baud Rate	115K baud
Operating Temperature	-40 C to 85 C
Certification	RoHS-Compliant, UL, CUL, CE Approvals, Class I Div 2
ENCLOSURE / HARDWARE	
Size	5.40" x 3.83" x 1.19"
Weight	7.6 oz
Enclosure Type	Anodized Aluminum
Mounting	Din rail or panel mount
LEDs	Power LED & 2 general purpose LEDs on side
GATEWAY FEATURES & FUNCTIONS	
Alarming	Set <, <=, >, >=, !=, and change-of-state rules on any data moving through the gateway. If alarm rule is triggered an email notification can be sent.
Gateway Security	You can configure up to 9 different users access to diagnostic and configuration screens.
Translation Table	Allows for data manipulation during protocol translation. Scaling and other data format changes can occur in the gateway.
Status and Counters	Protocol specific status, counters, and error messages are accessible within the gateway's diagnostics page. They can also be delivered to a connected device.
Diagnostic Logging Page	Allows users to see and log start up sequences, protocol specific messages & error messages.

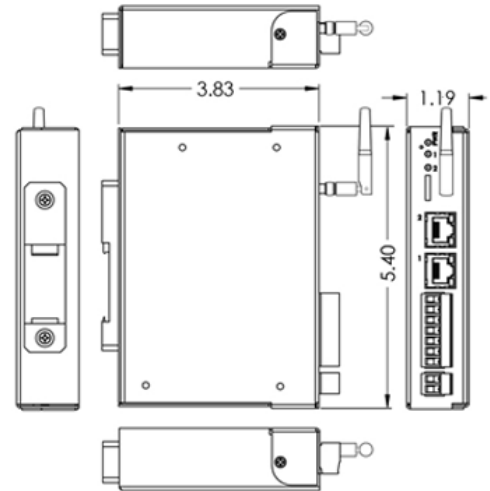

NOT EXACTLY WHAT YOU WERE LOOKING FOR?
 Real Time Automation offers a full line of gateway products. Give us a call at 1-800-249-1612. Or, check out a listing at www.rtautomation.com/products. We also offer customizations for unique applications.

CATALOG #	DESCRIPTION
460BSDFM-N2EW	Connects a BACnet/IP client with as many as 32 DF1 slaves



Made in the
U.S.A. 

Always In
Stock 

Ready to
Ship 

Expert
Support 